

**ONLINE HOTEL RESERVATION SYSTEM
CASE STUDY OF CRANE RESORT HOTEL- ISHAKA**

BY

KARUNGI SHAKIRA

BIT/0003/113/DU

**A PROJECT REPORT SUBMITTED TO THE FACULTY OF SCIENCE AND
TECHNOLOGY IN PARTIAL FULFILLMENT OF THE REQUIREMENT FOR THE
AWARD OF A BACHELORS DEGREE IN INFORMATION TECHNOLOGY OF**

KAMPALA INTERNATIONAL

UNIVERSITY

JULY, 2014

DECLARATION

I **KARUNGI SHAKIRA** do hereby declare to the best of my knowledge that this graduation project is my original work and it has never been submitted to any University or any other Institution of higher learning for any award.

Signed:.....*Shakira*.....Date: *31.7.2014*.....

KARUNGI SHAKIRA

APPROVAL

This project report entitled "Online Hotel Reservation System for Crane Resort Hotel" has been done and completed under my close supervision and is now ready for submission.

Signed 

Date: 

Mr. ALITWEZA JOSHUA

SUPERVISOR

DEDICATION

I dedicate this research to my beloved Dad who supported me even in times of difficulties, to my wonderful son Amany Ryan Larry and his Dad Frank Kato and to my brother Juma Bashir.

ACKNOWLEDGEMENT

I thank my lecturers who gave me knowledge, my great friends Winnie, Cathy, my beloved coursemate that is Allan, Dorcus, Patience, Jason, Bruce, my family members my relatives and to the whole entire community of KIU

TABLE OF CONTENTS

DECLARATION	ii
APPROVAL	iii
DEDICATION.....	iv
ACKNOWLEDGEMENT	v
TABLE OF CONTENTS	vi
CHAPTER ONE.....	1
INTRODUCTION	1
1.0 Introduction.....	1
1.1 Background of the study	1
1.2 Problem statement	1
1.3 General objective	1
1.4 Specific objectives	2
1.5 Research questions.....	2
1.6 Scope of the study.....	2
1.6.1 Content scope	2
1.6.2 Geographical scope	2
1.6.3 Time scope	2
CHAPTER TWO	4
LITERATURE REVIEW	4
2.0 Introduction.....	4
2.1 System Study and Analysis	4
2.2 Identifying requirements.....	4
2.2.1 Performance Requirements	5
2.3 Design of the new system	5
2.4 Testing, Implementation and Maintenance.....	5
2.4.1 Testing.....	5
2.4.2 Implementation.....	6
2.4.3 System Maintenance	6
CHAPTER THREE	8
METHODOLOGY	8

- 3.0 Introduction.....8
- 3.1 Study Area8
- 3.2 Study participants8
- 3.3 Study population.....8
- 3.4 Sample size8
 - 3.4.1 Sampling method.....8
- 3.5 Requirements' design8
- 3.6 Data sources.....9
- 3.7 Data collection Methods/instruments9
- 3.8 Data Analysis.....9
- 3.9 System design10
 - 3.9.1 Designing the Prototype10
- 3.10 Ethical Considerations10
- CHAPTER FOUR11
- SYSTEM ANALYSIS AND DESIGN11
- 4.1 System Analysis.....11
 - 4.1.1 User Interface Requirements11
 - 4.1.2 Database Requirements12
 - 4.1.3 Functional Requirements.....12
 - 4.1.4 Functional Requirements.....13
 - 4.1.5 Other Requirements.....13
 - 4.1.6 Design Requirements13
- 4.2 System Design14
 - 4.2.1 Architectural Design.....14
 - 4.2.2 Process Design14
 - 4.2.3 Entity Relationship Diagram14
 - 4.2.4 Cardinality and Modality:15
 - 4.2.5 Modality:16
 - 4.2.6 Entity Relationship Diagram showing all entities.....16
 - 4.2.7 Another Entity Relationship diagram showing the way customers are related to the hotel and users.....17

4.2.8 Data Flow Diagram Showing the Flow of Customers' Information.....18

CHAPTER FIVE19

PROJECT TESTING, IMPLEMENTATION AND MAINTAINANCE19

5.0 Introduction.....19

5.1 Levels of Testing19

5.1.1 Table shows the Tests Conducted on the System.....19

5.1.2 Unit Testing20

5.1.3 Module Testing.....20

5.1.4 Integration Testing20

5.1.5 Acceptance Testing20

5.1.6 Web Design Constraints20

5.2.1 Log in window21

5.2.2 The home page21

5.2.3 The page that displays the customer details22

5.2.4 Administrator Menu22

5.2.5 The Reservation Form.....23

5.2.7 Customer Comments Form24

5.2.8 Exiting customer form.....25

CHAPTER SIX.....26

DISCUSSIONS, CONCLUSION AND RECOMMENDATIONS26

6.0 Introduction.....26

6.1 Discussions26

6.2 Conclusion26

CHAPTER ONE

INTRODUCTION

1.0 Introduction

This chapter basically looks at the background of the study, objectives, research questions, scope and significances of the study.

1.1 Background of the study

Efficient hotel reservation is a crucial factor for the success of hotel organizations and thus has gained increased attention among tourism researchers and various definitions can be found. Three main waves of technological developments changed distribution systems in hotel enterprises, namely computer reservation systems (CRS) in the 1970s; Global distribution systems (GDS) in the 1980s and the Internet in the 1990s (Buhalis, 1998). The major technological progress in the distribution industry was the Internet. The internet commenced operation in 1969 with four universities connected, mainly for research and military purposes (Werthner and S. Klein, 1999a). The commercial usage of the Internet began years later, when companies started to take advantage of the communication protocol of the world wide web, which in 1993 has been made freely accessible to the public (Kracht and Wang, 2010). After the public entrance of the Internet, it has grown as a network of networks and currently records 2.3 billion users worldwide. This represented about 33% of the population worldwide and a 58.1% growth compared to the year 2000 (World Usage Patterns & Demographics, 2012). Throughout the world there has been a tremendous growth in the use of the web. The Internet provides 24/7 accessibility and allows travelers to undertake reservations online in a short period of time, at much lower costs and in a more convenient way than with traditional methods.

1.2 Problem statement

The Reservation system at crane resort hotel is manual handled for booking and enquiry. This is time consuming, expensive and inefficient where by a person has to go physically to the hotel for booking and enquiry. Upon this ground, the researcher has come with software which is online hotel reservation system that provides online facility for hotel booking and enquiry. Thus saving customer time to go the hotel for booking.

1.3 General objective

To design an Online Hotel Reservation system for Crane Hotel booking, reservation and enquiries

1.4 Specific objectives

1. To study and analyze the current manually hotel reservation system
2. To identify the requirements needed to come up with an online reservation system
3. To design a new online hotel reservation system for crane hotel
4. To test, implement and maintain the designed system at crane hotel

1.5 Research questions

1. What study and analysis have been made on the current manual reservation system?
2. What are the requirements needed to come up with an online reservation system?
3. What designs are needed for a new online hotel reservation system for crane hotel?
4. What tests and implementation methods can be used at crane hotel?

1.6 Scope of the study

1.6.1 Content scope

The study mainly looks at the way customers have been making bookings at crane resort hotel ishaka.

1.6.2 Geographical scope

Crane resort hotel the biggest hotel in ishaka town located along Ishaka -Kasese road, opposite Kaburengye church of Uganda towards Kizinda trading center. It started in 2006 under the management of Mr. Tumusiime Joab commonly known as JB.

1.6.3 Time scope

The study will look at the way crane resort hotel has been handling its bookings for hotel services since 2010 to 2014.

1.7 Significances of the study

The study will help the crane hotel customers to save their time by sitting at home and make reservations on line.

The study will help the administrators of crane resort hotel to know how many customers they have on a daily basis by having daily reports.

The study will also help workers to monitor the bookings on line without any paper work involved.

The study will benefit the researcher to fulfill her requirement in Bachelor of Information Technology.

CHAPTER TWO

LITERATURE REVIEW

2.0 Introduction

This chapter basically explains the objectives of the study as cited by other authors.

2.1 System Study and Analysis

Overview of the Existing System

In the existing system user can face so many problems.

- ❖ They have to waste so much time for the reservation of the room.
- ❖ For reserving a room, customer has to go to the hotel physically.
- ❖ This is a very time consuming task.
- ❖ Sometimes the user is very tired then feels lazy to take records of the customer and this is a failure for the existing system.

System analysis is the process of gathering and interpreting facts, diagnosing problems and using the facts to improve the system. System specifies what system should do. A system is a set of components that interact to accomplish some purpose.

2.2 Identifying requirements

Software requirement specification abbreviated as SRS is a means of translating the idea of files into a formal document. The main features of SRS include:

- ❖ Establishing the basis for an agreement between the client and the developer.
- ❖ Producing a reference for validation of the final product. SRS assist clients in determining if the software meets the requirements.

Mainly there are six requirements which an SRS must satisfy.

- (a) It should specify the external behavior.
- (b) It should specify the constraints.
- (c) It should be easy to change.
- (d) It should be a reference tool.
- (e) It should record throughout the lifecycle.
- (f) It should have the capacity of expectation of an undesired event.

Usually we come across **four types of requirement** specification

- (a) User Interface Requirements
- (b) Database Requirements

- (c) Functional Requirements
- (d) Non-Functional Requirements

2.2.1 Performance Requirements

- (a) The database should be centralized and secure.
- (b) The system should be user friendly and easily accessible
- (c) The system must be reliable.

2.3 Design of the new system

System design provides the understanding and procedural details necessary for constructing and implementing the system recommended in the system study. Emphasis is on translating the performance requirements into design specifications. The Design phase is a transition from a user – oriented document (System proposal) to a documented oriented to the programmers or database personnel.

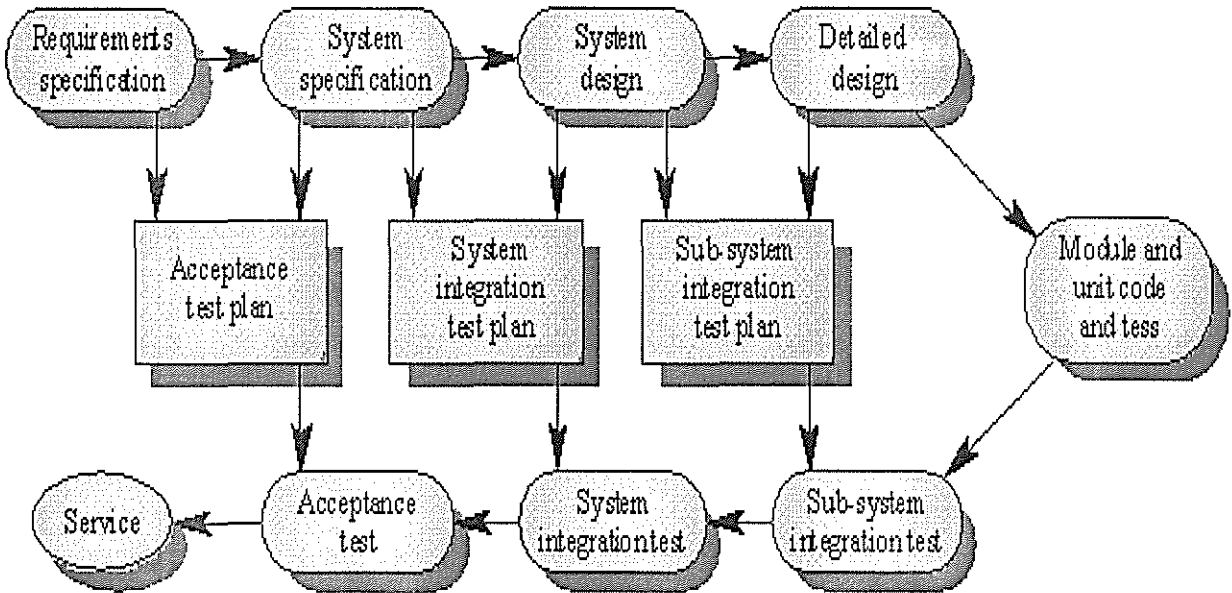

The figure shows the cycle that the new system must go through before it is used. Adopted from; (Ian Somerville, 2000)

2.4 Testing, Implementation and Maintenance

2.4.1 Testing

Software testing is a critical element of software quality assurance and represents the ultimate review of specification, design and coding. In fact, testing is the one step in the software engineering process that could be viewed as destructive rather than constructive.

A strategy for software testing integrates software test case design methods into a well-planned series of steps that result in the successful construction of software. Testing is the set of activities that can be planned in advance and conducted systematically. The underlying motivation of program testing is to affirm software quality with methods that can economically and effectively applied to both strategic to both large and small-scale systems

2.4.2 Implementation

A crucial phase in system development is the successful implementation of the new system design. Implementation includes all those activities that take place to convert from the old system to the new system to the new system. The new system may be completely new replacing an existing manual or automated system or it may be major modification to an existing system.

In either case proper implementation becomes necessary so that a reliable system based on the requirement of the organization can be provided. Successful implementation may not guarantee improvement in the organization using the new system, but improper installation will prevent this improvement.

It has been observed that even the best system cannot show good results if the analysts managing the implementation do not attend every important detail. This is the area where the system analysts need to work with utmost care.

2.4.3 System Maintenance

System maintenance is the modification of a software product after delivery to correct faults, to improve performance or other attributes, or to adapt the product to a modified environment. Maintenance is thus a very broad activity often defined as including all work made on a software system after it becomes operational.

Maintenance covers large number of activities like the correction of errors, the enhancement, deletion and addition of capabilities, the adaptation to changes in data requirements and operation environments, the improvement of performance, usability, or any other quality attribute. Maintenance accounts for 50-80 percent of total system development. To put

maintenance in its proper perspective requires considerable skill and experience and is an important and ongoing aspect of system development. Maintenance demands more orientation and training than any other programming activities. The environment must recognize the needs of the maintenance programmer for tools, methods and training.

Maintenance is done after the successful implementation of the software and is continued till the product is reengineered or deployed to another platform. Maintenance is also done based on fixing the problems reported, changing the interface with other software or hardware enhancing the software.

CHAPTER THREE

METHODOLOGY

3.0 Introduction

This chapter describes the methodology that was used to carry out the study that led to the design of an online hotel reservation system.

3.1 Study Area

The study mainly looked at Crane Resort hotel and the way customers make their bookings.

3.2 Study participants

The study consisted of customers, and staff of Crane Resort Hotel.

3.3 Study population

The study comprised a population of 150 people.

3.4 Sample size

Sample size from the population using the random sampling method was 70 respondents where by 50 customers and 20 staff members were selected.

3.4.1 Sampling method

Random sampling was used because the researcher was interested in making inferences about the population. The researcher intended to identify a suitable sample frame (list of target population-customers and staff).

3.5 Requirements' design

Requirements gathering and specification could not be achieved in a single day. This therefore called for use of the iterative model which allowed users chance to continue bringing in new requirements for the system. This helped to increase user satisfaction and build user trust in the system.

3.6 Data sources

The researcher intended to gather both primary and secondary data using primary and secondary data sources which included hotel magazines, booking forms, brochures, text books on online systems, articles and the internet.

3.7 Data collection Methods/instruments

- **Interviews**

The researcher designed an interview guide to enable the carrying out of semi-structured interviews. This was designed basing on the sample size. The researcher interviewed some directors, support staff and customers of the hotel. Using this method of data collection, the researcher achieved objective (I) which was; to review literature related to the system developed with an aim of gaining more understanding of the current issues in this field and specifying the user requirements for the online hotel reservation management system

- **Questionnaires**

The researcher designed questionnaires to use in data collection. This helped in information gathering and recording from the sample that was selected. These were distributed accordingly and the research used this method to achieve objective (ii) and (iii) which involved requirements gathering and system design creation.

- **Observation**

An observation form was designed to enable the researcher observe the way the existing system used to book and reserve places for customers at crane resort hotel I.e. The researcher observed the activities at the Crane resort hotel with an aim of understanding the sequence of activities. She also observed how customers used to come and book manually.

3.8 Data Analysis

The data obtained from the data collection stage was subjected to analysis using tools like excel (to perform quantitative analysis), ERDs and DFDs. DFDs show the logical flow of the data and the processes involved in the system. ERDs, which are the main tools for data modeling, used to model the relationship between the different entities.

.9 System design

This is concerned with the system lay out without neglecting the required input to produce the desired output.

3.9.1 Designing the Prototype

Design of the system was done using the requirements specified at the analysis stage. It was addressed in the following ways.

Input and output

This included texts, images and the application system output structured data such as reports.

3.10 Ethical Considerations

The researcher informed the Crane hotel manager that she is a student intending to carry out her research at the hotel. The researcher obtained a letter from the department which she took to Crane resort hotel director asking him to carry her research at the Hotel. The researcher then went to the staff and customers of Crane resort hotel whom she explained to the purpose of research and they accepted to give all the necessary information.

CHAPTER FIVE

PROJECT TESTING, IMPLEMENTATION AND MAINTAINANCE

5.0 Introduction

This is the construction of the new system and the delivery of the system into production i.e. day-to-day operation.

5.1 Levels of Testing

Testing is usually relying on to detect the faults on each phase, in addition to the faults introduced during the coding phase itself. Due to this, different levels of testing are used in the testing process, each level of testing aims to test different aspect of a system.

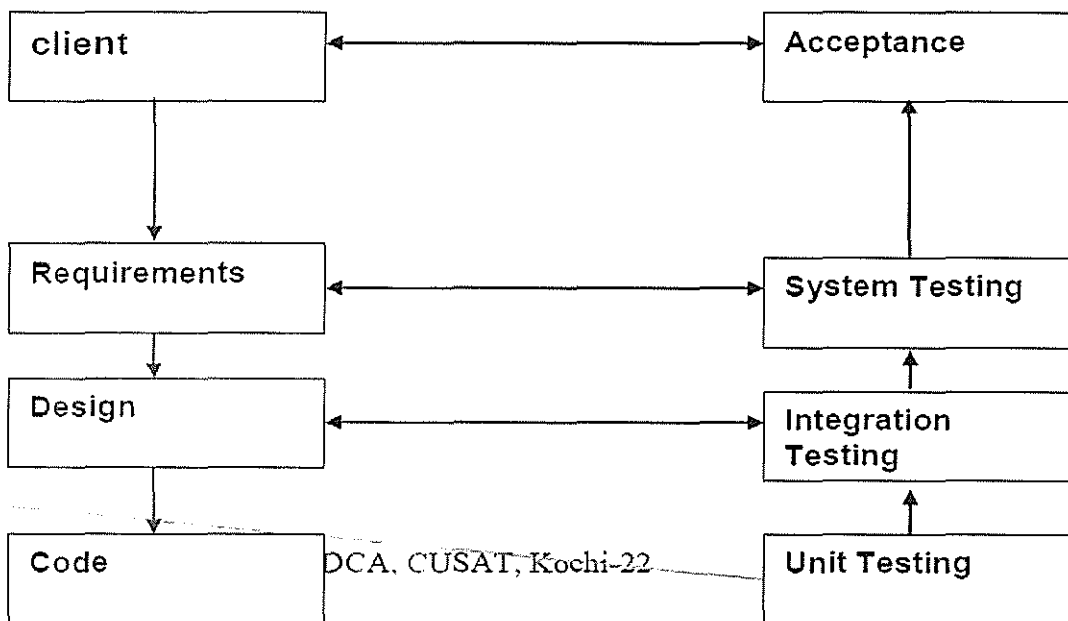

Table Given below outlines the tests that were performed on the system to ensure correctness and unearth errors, which were subsequently debugged.

5.1.1 Table shows the Tests Conducted on the System

Testing Phase	Objectives
Unit Testing	The various functions within each program and the program blocks are tested for proper working.
Module Testing	A module is composed of various programs related to that module. Module testing is done to check the module functionality and interaction between units within a module
Integration Testing	Integration testing is done to test the functionality and interfacing

	between the modules.
Acceptance Testing	Acceptance testing is done after implementation to check if the system runs successfully in the customer environment/site.

5.1.2 Unit Testing

Unit Testing was done to test field validations, navigation, functionality of the programs and its blocks. These tests are applied on various functions within each program and other critical program blocks.

5.1.3 Module Testing

Module testing was done to test the interaction between the various programs within one module. It checks the functionality of each program with relation to other programs within the same module. It then tests the overall functionality of each module.

5.1.4 Integration Testing

Integration testing is done to test the functionality and interfacing between the modules. The system is built up of various modules, which work together to automate the activities of the hotel management system. These modules should work together in a seamless way to achieve the desired results. Integration testing tested for this property of the modules. The modules display a cause and effect relationship, if data in one module is changed, then it affects the data to change in some other module also. Integration testing needs to check if the modifications do not adversely affect some other modules.

5.1.5 Acceptance Testing

Acceptance testing was done after the implementation of the system. The acceptance testing checks if the system works correctly in the user environment and if the entire user specified functionalities are present. It also tests if the system adheres to the company policies and quality standard.

5.1.6 Web Design Constraints

The following design constraints were kept in mind while designing the pages for the whole application:

The pages should be consistent and easy to operate. It should be designed in such a way that an average user who does not have much idea about JSP and related technology can still be able to access the information needed.

5.2 Implementation Interfaces

5.2.1 Log in window

This is the first window displayed which requires the administrator to log into the system.

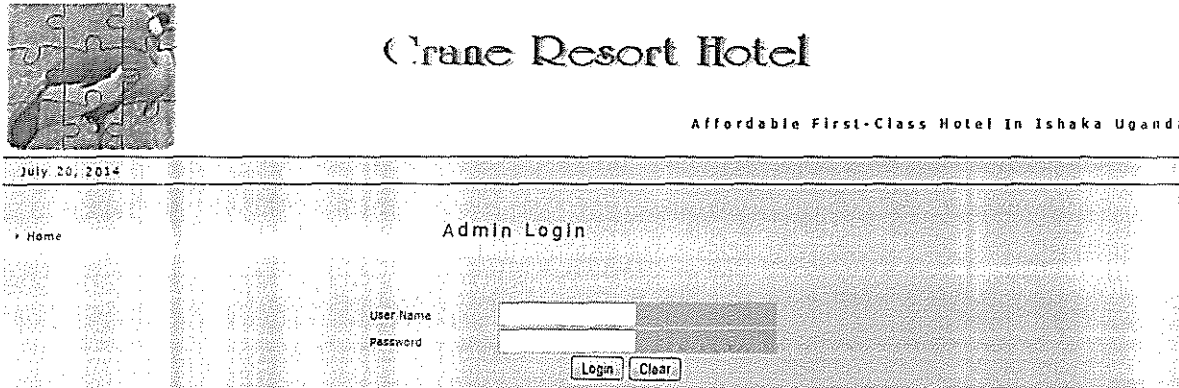

5.2.2 The home page

This displays the welcome page to the customer where the user makes a choice on the activity needed.

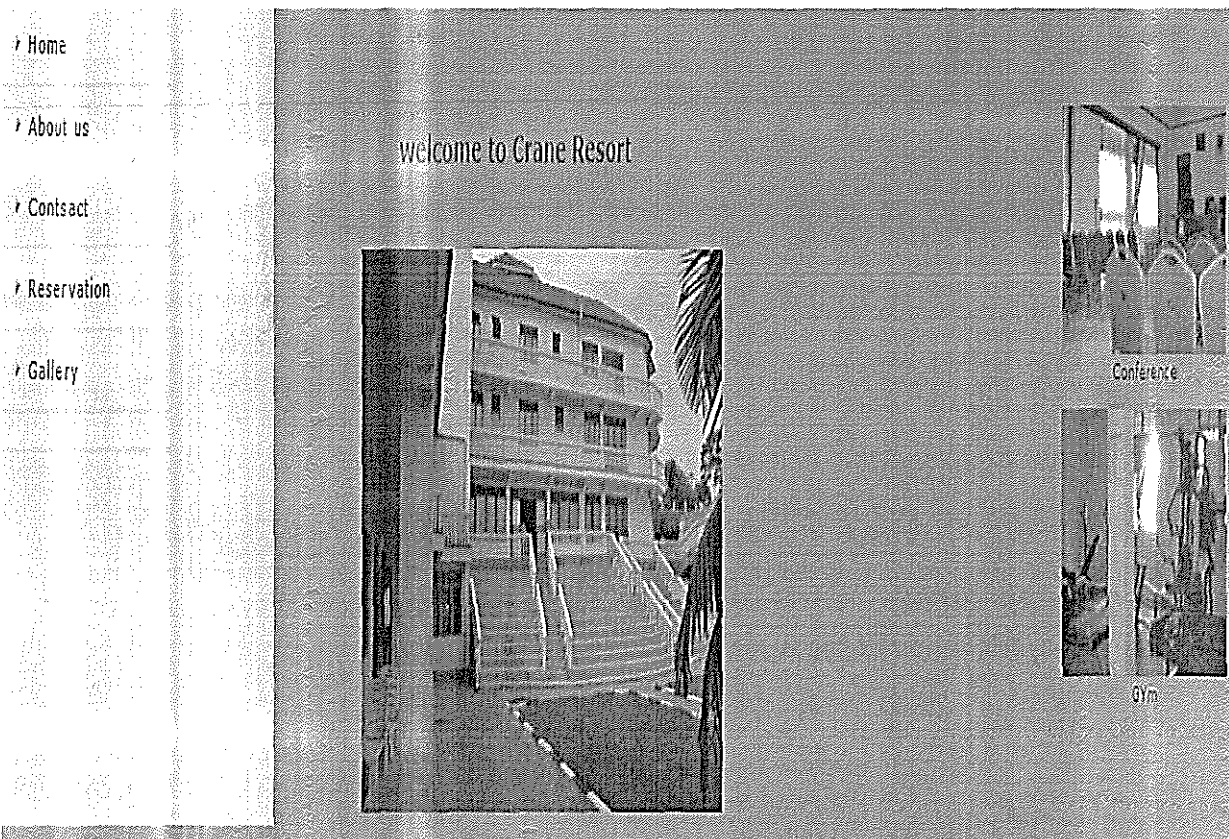

List of references

- Adams, D.A., Nelson, R.R. and Todd, P.A. (1992), *Perceived Usefulness, Ease of Use, and Usage of Information Technology: A Replication*, MIS Quarterly, Vol. 16
- Ahn, T., Ryu, S. and Han, I. (2007), *The impact of Web quality and playfulness on user acceptance of online retailing*, Information & Management, Vol. 44 No. 3
- Atkinson, A. (1988), *Answering the eternal question: what does the customer want?*, The Cornell Hotel and Restaurant Administration Quarterly, Vol. 29 No. 2
- Atkinson, M.A. and Kydd, C. (1997), *Individual characteristics associated with World Wide Web use: an empirical study of playfulness and motivation*, Data Base for Advances in Information Systems, Vol. 28 No. 2, pp. 53–62.
- Ayeh, J., Leung, D., Au, N. and Law, R. (2012), *Perceptions and Strategies of Hospitality and Tourism Practitioners on Social Media:*
- Barnett, L. A. (1990), *Playfulness: definition, design, and measurement*, Play and Culture, Vol. 3 No. 4, pp.319–336.
- Benkert, M. (2012a), *Google Hotel Finder in Deutschland gelandet*, be-con.de, from <http://www.be-con.de/135/blog/google-hotel-finder-in-deutschland-gelandet.html>
- Benkert, M. (2012b), *Der Google Hotel Finder ist da. Und nun?*, be-con.de. from <http://www.be-con.de/135/blog/der-google-hotel-finder-ist-da-und-nun-.html>
- Bennett, M. M. and Lai, C.-W.K. (2005), "Academic papers: The impact of the internet on travel agencies in Taiwan," *Tourism and Hospitality Research*, Vol. 6 No. 1, pp. 8–23.
- Bieger, T. and Laesser, C. (2004), *Information Sources for Travel Decisions: Toward a Source Process Model*, Journal of Travel Research, Vol. 42 No. 4, pp. 357–371.
- Cantoni, Lorenzo, Farée, M., Inversini, A. and Passini, V. (2011), *Hotel Websites and Booking Engines : Information and Communication Technologies in Tourism 2011*
- Chen, L., Gillenson, M. L. and Sherrell, D. L. (2002), *Enticing online consumers: an extended technology acceptance perspective*, Information & Management, Vol. 39 No. 8, pp. 705–719.

Cho, J. (2004), *Likelihood to abort an online transaction: influences from cognitive evaluations, attitudes, and behavioral variables*, Information & Management, Vol. 41 No. 7, pp. 827–838.

Christodoulidou, N., Connolly, D. J. and Brewer, P. (2010), *An examination of the transactional relationship between online travel agencies, travel meta sites, and suppliers*, International

Constantinides, E. (2004), *Influencing the online consumer's behavior: the Web experience*, Internet Research, Vol. 14 No. 2, pp. 111–126.

Davis, F. D. (1986), *A technology acceptance model for empirically testing new end-user information systems: theory and results*, MA.

Davis, F. D., Bagozzi, R. P. and Warshaw, P. R. (1989), *User Acceptance of Computer Technology: A Comparison of Two Theoretical Models*, Management Science, Vol. 35 No. 8, pp. 982–1002.

Davis, F. D., Bagozzi, R.P. and Warshaw, P.R. (1992), *Extrinsic and Intrinsic Motivation to Use Computers in the Workplace*, Journal of Applied Social Psychology, Vol. 22 No. 14, pp. 1111–1132.

Deci, E. L. and Ryan, R. R. (1985), *Intrinsic Motivation and Self- Determination in Human Behavior*, NewYork, Plenum-Press.

Go, F.M. and Pine, R. (1995), *Globalization Strategy in the Hotel Industry*, New York, Routledge.

Green, C.E. and Lomanno, M.V. (2012), *Distribution Channel Analysis: a Guide for Hotels*.

Law, R. and Leung, R. (2000), *A Study of Airlines' Online Reservation Services on the Internet*, Journal of Travel Research, Vol. 39 No. 2, pp. 202–211.

Lederer, A. L., Maupin, D. J., Sena, M. P. and Zhuang, Y. (2000), *The technology acceptance model and the World Wide Web*, Decision Support Systems, Vol. 29

Lee, M.-C. (2009), *Factors influencing the adoption of internet banking: An integration of TAM and TPB with perceived risk and perceived benefit*, Electronic Commerce Research and Applications, Elsevier B.V.,

Willis, T. J. (2008), *An Evaluation of the Technology Acceptance Model as a Means of Understanding Online Social Networking Behavior*, University of South Florida.

Wong, J. and Law, R. (2005), *Analysing the intention to purchase on hotel websites: a study of travellers to Hong*

Yi, M.Y. and Hwang, Y. (2003), *Predicting the use of web-based information systems: self-efficacy, enjoyment, learning goal orientation, and the technology acceptance model*, *International Journal of Human-Computer Studies*, Vol. 59, pp. 431–449.

Yoon, S.-J. (2002), *The antecedents and consequences of trust in online-purchase decisions*, *Journal of Interactive Marketing*, Elsevier, Vol. 16 No. 2, pp. 47–63.